



Advanced Photon Source Upgrade

Advanced Photon Source Upgrade Project

Final Design Report

May 2019

Chapter 6: Storage Ring Utilities

Document Number : APSU-2.01-RPT-003

ICMS Content ID : APSU_2032071

Table of Contents

6 Storage Ring Utilities	1
6-1 Introduction	1
6-2 Electrical Power, Lighting, Fire Alarm, and Telephone Systems	1
6-3 Heating, Ventilation, and Air Conditioning System	2
6-4 Cooling Water System	2
References	7

List of Figures

Figure 6.1: Storage ring recirculating air system.	3
Figure 6.2: Storage ring outdoor air system.	3
Figure 6.3: Schematic of (copper) cooling water system.	5
Figure 6.4: Schematic of “aluminum” cooling water system.	6

Acronyms and Abbreviations

AC	Alternating Current
APS	Advanced Photon Source
Argonne	Argonne National Laboratory
DC	Direct Current
DDC	Direct Digital Control
DI	Deionized
DP	Differential Pressure
FM	Flow Meter
HVAC	Heating, Ventilation, and Air Conditioning
HX	Heat Exchanger
MBA	Multi-Bend Achromat
PLC	Programmable Logic Controller

6 Storage Ring Utilities

6-1 Introduction

The storage ring utilities include the facility utility power and lighting; heating, ventilation, and air conditioning (HVAC); cooling water; and compressed air systems. The current HVAC system for the tunnel meets the Project requirements. The HVAC system will remain functional in the storage ring tunnel during the removal and installation work. Alternating current (AC) outlet power, overhead lighting, and the compressed air system will also remain functional. A small nitrogen header is being considered as an addition in the storage ring tunnel. The following is a description of the main systems for the existing storage ring utilities.

6-2 Electrical Power, Lighting, Fire Alarm, and Telephone Systems

Electrical power for all power panels associated with the storage ring is provided by switchgears SG-A1, SG-X1, SG-X2, SG-X3, SG-X4, SG-X5, SG-X6, SG-X7, SG-X8, and SG-X9 in Building 400. All storage ring power for general infrastructure is provided by local power panels located on top of the storage ring.

An equipment grounding system is provided from connections on each piece of equipment to ground conductors running with all power feeders. From the main building switchboard ground bus, a copper cable is connected to the building water main. In addition, all computer and related equipment is provided with a separate quiet grounding system that is isolated from the other grounding systems and is connected to a separate counterpoise and ground rod system.

The storage ring is lighted by 2-lamp, 4-ft, wall-mounted, fluorescent fixtures mounted on 8-ft centers on both sides of the enclosure, and is switched from the lighting panels. This lighting system will remain in use for APS-U. Duplex receptacles are mounted on 50-ft centers, 3 ft above the finished floor on both perimeter walls of the ring. Smoke detectors are installed throughout the enclosure and in the HVAC system. The alarm system is annunciated at the Argonne fire station and at the APS security point in the main control room. Telephone outlets are provided at 20 locations within the storage ring enclosure and at 20 locations atop the enclosure, all distributed uniformly around the ring.

Lighting is provided at 277 V by local lighting panels (277/480 V) mounted on the storage ring mezzanine. Emergency lighting is provided by emergency battery pack light fixtures, which are located outside of the storage ring but have remote heads located inside the storage ring. The emergency battery packs are connected to local lighting circuits in the storage ring and provide normal lighting power within the area that the emergency battery pack serves so that if the normal power lighting circuit is lost, the emergency battery pack light fixture will turn on and provide emergency illumination.

General power in the storage ring is provided by local 120 V receptacles mounted on the storage ring walls and is served from local receptacle panels and technical receptacle panels (120/208 V)

located on the storage ring mezzanine.

Welding receptacles in the storage ring provide 50 A, 480 V service. Local heavy-duty disconnect switches are mounted on the storage ring walls. These switches are served from local technical power panels (277/480 V) located on the storage ring mezzanine.

All of this general power infrastructure shall remain as is for the Advanced Photon Source (APS) Upgrade.

6-3 Heating, Ventilation, and Air Conditioning System

The storage ring enclosure is air-conditioned to maintain a space temperature of $75^{\circ}\text{F} \pm 2^{\circ}\text{F}$ year-round. Twenty fan coil units located throughout the enclosure provide cooling to maintain the space temperature. Slots in the wall near the roof of the enclosure allow ventilation air to flow from the experiment hall into the enclosure, and thirty $3,600\text{-ft}^3/\text{min}$ exhaust fans located on the roof of the experiment hall exhaust air from various points in the storage ring enclosure. These units operate continuously on low speed, but are switched to high-speed operation to function as smoke-purge units if smoke is detected in the enclosure. No space humidification is provided. Chilled water and steam are supplied from a connection to the utility loop above the storage ring. A DDC in this building controls the HVAC equipment.

The APS storage ring is served by 20 constant-volume air handling units. Each unit is provided with a hot water preheat coil, duplex tertiary heating water pumps, filter bank, and chilled water-cooling coil. The units are divided into two categories. The first consists of 16 units that recirculate air with cooling only to provide temperature stability within the sectors that they control. See Figure 6.1. Temperature control is maintained by varying the supply air temperature to match the cooling requirements of each zone. Each of the 16 units also exhausts a fixed percentage of the air to maintain the storage ring under a slight negative pressure.

The second category consists of four units that provide cooling, dehumidification, and outdoor make-up air with preheating as required by outdoor air conditions. These units have been retrofitted with customized reheat coils to permit dehumidification of the outdoor make-up air. See Figure 6.2.

The temperature control of the zones served by these units is maintained by the retrofit reheat coils. These coils use a low-grade (temperature) waste heat source to reset the cold dehumidified air supplied by the unit.

Currently, all 20 storage ring zones operate within a nominal temperature range of 0.8°F peak to peak. This condition meets the current requirement for temperature stability for APS-U.

6-4 Cooling Water System

The deionized (DI) cooling water system in the storage ring tunnel will need to remove the heat generated by two primary sources: (1) resistive heat in the magnet coils and (2) heat caused by synchrotron radiation. The design power consumptions for the magnets in the multi-bend achromat (MBA) lattice have been compared to the design consumption values of the existing APS storage magnets, and it is estimated that 80% of the total power to the magnet/power-supply system is

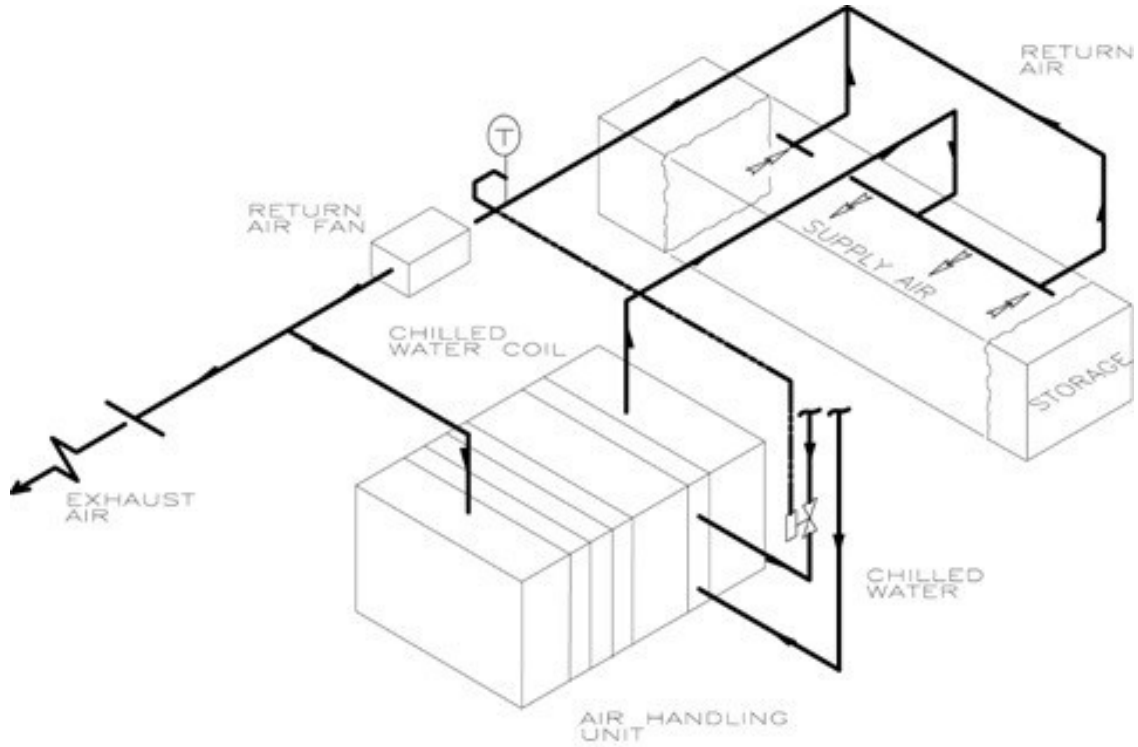

Figure 6.1. Storage ring recirculating air system.

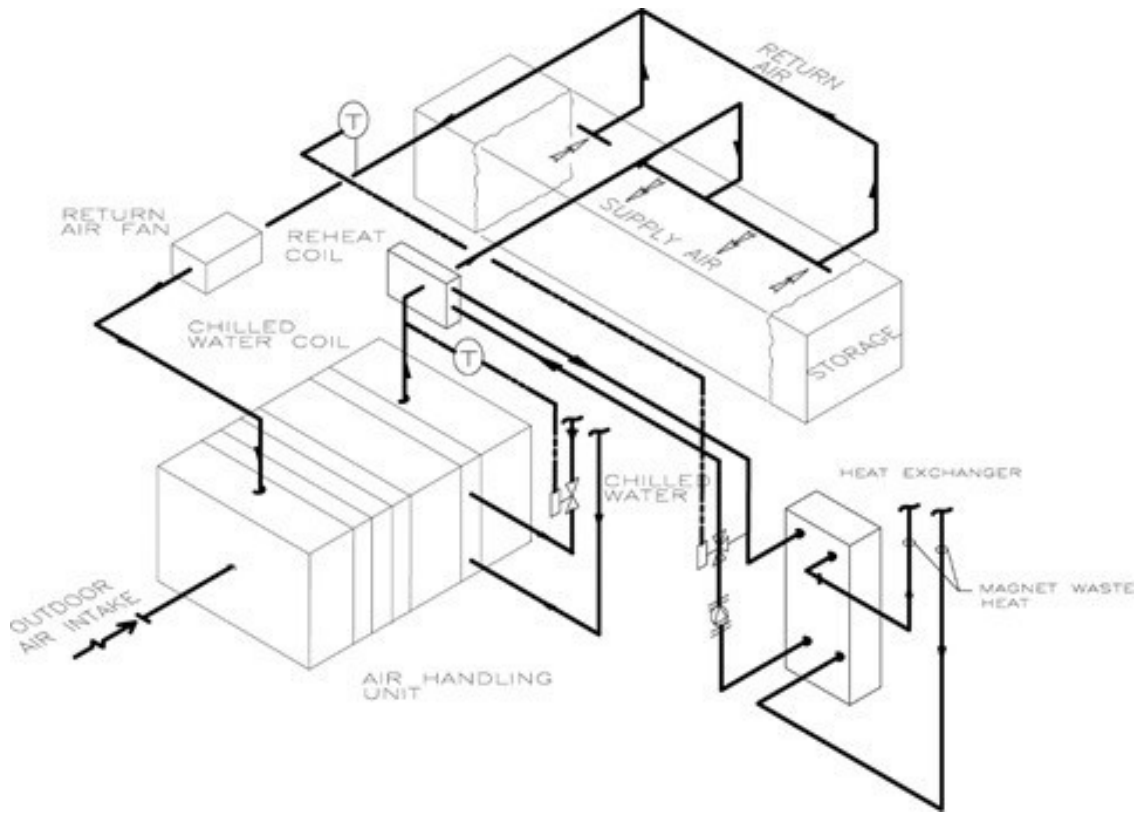

Figure 6.2. Storage ring outdoor air system.

dissipated in the magnets, with the remainder dissipated in the power converters and direct current (DC) cables. The MBA magnet/power-supply systems is expected to require less total power than those of the existing storage ring. A final estimate of power consumption will be done after all magnets are designed.

The heat generated by synchrotron radiation in the MBA lattice has been calculated to be 420 kW for the entire storage ring. This value includes power lost to the chamber walls and absorbers. The existing DI water system used for the storage ring magnets operates at a head pressure of 150 psig at the pump outlets. The average pressure difference (ΔP) across the existing magnets is 104 psig. The new MBA magnets are designed to have a ΔP of 90 psi.

Water pH is not currently measured. It is planned to install a pH meter in the fall. It will be possible to improve temperature control to $\pm 0.1^\circ\text{F}$ for the "copper" (magnet) water system and to $\pm 0.01^\circ\text{F}$ for the "aluminum" water system, which can be used for the new MBA vacuum chamber. The need for this improvement has not been firmly established yet.

There are currently separate DI cooling water systems for copper components [1], such as magnet coils and absorbers, and for aluminum components [2], such as the main and insertion device vacuum chambers. There are 20 "copper" water systems and 20 closed-loop "aluminum" water systems.

These secondary water systems are part of the primary-secondary DI water system that supplies water to magnets, absorbers, power supplies, and beamline user equipment. Each of the secondary water systems (see the "copper" water system shown schematically in Figure 6.3) has a nominal capacity of 450 gpm at a pressure differential of 90-100 psid and consists of two pumps in lead/stand-by arrangement, where one of the pumps is equipped with a variable speed drive. Temperature control is accomplished by mixing of primary water and return water through use of a programmable logic controller (PLC) modulating valve; temperature is controlled to $\pm 0.2^\circ\text{F}$. A bypass control valve designed to maintain differential pressure (DP) and to limit supply pressure along with a hardwired high pressure switch is also part of the system. Full pump flow is filtered down to $0.5\ \mu\text{m}$, and resistivity of the water is monitored at selected secondary systems. Supply and return flow meters (FMs) monitor system performance and are also used for leak detection, and they shut the pumps off in the event of supply/return flow difference reaching an adjustable set point. The "copper" water system supplies requirements are in the process of being evaluated as lower flow rates and lesser heat rejection loads are expected with the new machine.

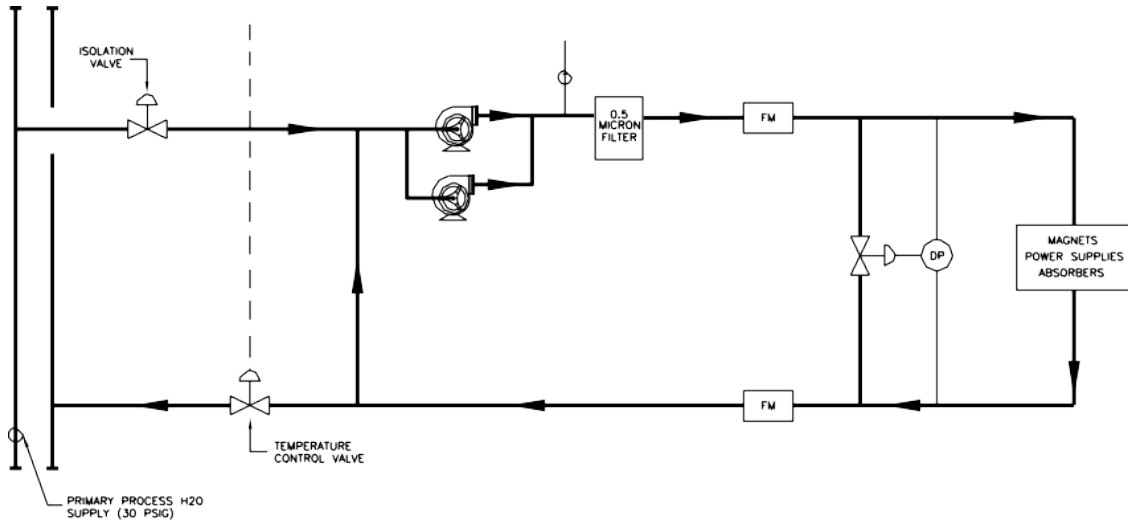

Figure 6.3. Schematic of (copper) cooling water system.

Vacuum chamber cooling skids (see the "aluminum" water system shown schematically in Figure 6.4) supply water for cooling of aluminum components. Each of 20 vacuum chamber cooling skids comprise an independent closed-loop system consisting of two pumps that operate in turn. One pump is always available for stand-by operation with nominal capacity of 50 gpm at 10 psid available inside the storage ring. Changes will be required for the aluminum water systems, as less flow and a smaller pressure differential are needed for the new vacuum chambers.

A shell-and-tube heat exchanger is used to reject heat from the process into the chilled water system. A polishing system utilities mixed bed resin to keep the water system at resistivity above 12 megohm-cm. Ultraviolet light treatment is used for bacterial control. Full pump flow filtration is provided at 0.5 μm particle size. Temperature is controlled at $78^{\circ}\text{F} \pm 0.1^{\circ}\text{F}$ by modulating the control valve and varying chilled water flow through the skid's heat exchanger (HX) under the supervision of a PLC controller.

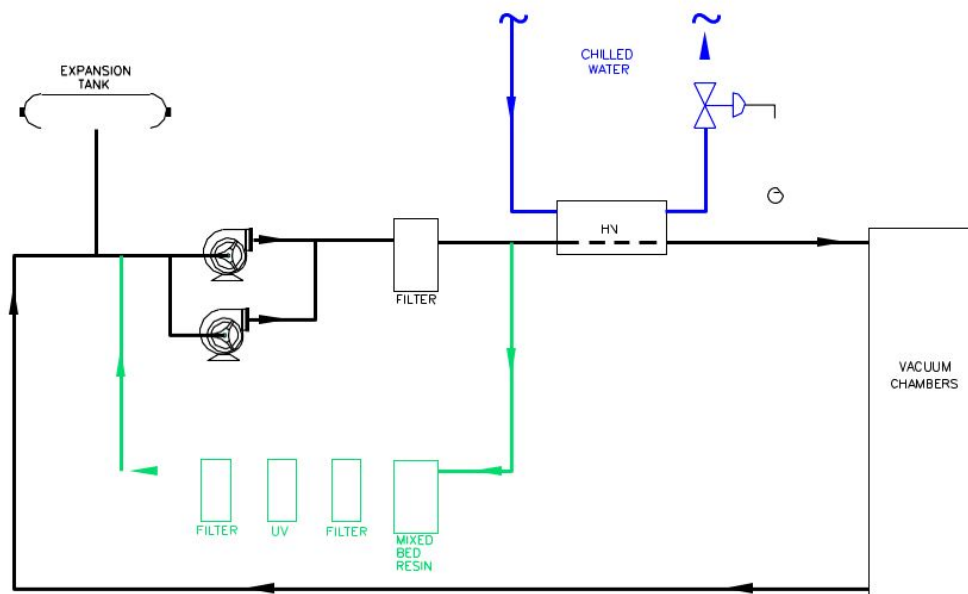

Figure 6.4. Schematic of “aluminum” cooling water system.

References

- [1] B. Roche. Copper Cooling Water PID, APS DWG U221020903-100001, Argonne National Laboratory, Argonne, IL, 2016.
- [2] B. Roche. Aluminum Vacuum Chamber Cooling Water PID, APS DWG U221020903-100000, Argonne National Laboratory, Argonne, IL, 2016.